

PERFORMANCE DATA SHEET EPACT NR CAN NEMA 12 - 11

Catalogue #: **JPP-36**

HP	kW	Voltage	S.F. @ 60Hz	EFF.	P.F.	Frame	Design	L.R. Amps
15	11.19	575	1.15	90.2%	0.86	254JP	B	93

60 Hz								Code	F.L. RPM
FLA									
208	230	416	460	480	575	600		G	3540
/	/	/	/	/	14	/			

50 Hz								Code	F.L. RPM
FLA			S.F. @ 50Hz	Efficiency	Power Factor				
190	380	415							
/	/	/	/		/	/	/	/	/

Wgt. Lbs	PH	Duty	Insul. Class	Amb.	Elevation	Temp. Rise° C
253	3	Cont.	F	40°C	1000M (3300 Ft)	52

% Efficiency		% Power Factor		Torque		Winding Resist. Ω	Safe Cold Start (Secs)
Full Load:	90.2%	Full Load:	0.86	Full Load Ft/Lbs	22.4		
3/4 Load:	90.5%	3/4 Load:	0.82	Locked Rotor %	210		
1/2 Load:	89.8%	1/2 Load:	0.73	Break Down %	270	1.02	20

Rotor Inertia Wk2 Lb-Ft2	Max Load Inertia Wk2 Lb-Ft2	Shaft Material	Frame Material	DE Bracket Type	ODE Bracket Type	Enclosure	NEMA Rating	Lead Wire Size
0.90	22.4	Standard	Cast Iron	Standard	Standard	TEFC	IP55	12AWG

Ball Bearings		Grease	Mount Type	Orientation	Paint	Sound Pressure @ 3FT	Sound Power
DE	ODE						
6309	6309	Mobil PolyrexEm	Rigid	Horizontal	Blue	84	94

Inverter Duty. Motor meets MG1 parts 31.4.4.2	Constant Torque Range	Variable Torque Range	Constant HP RPM
		2:1	10:1

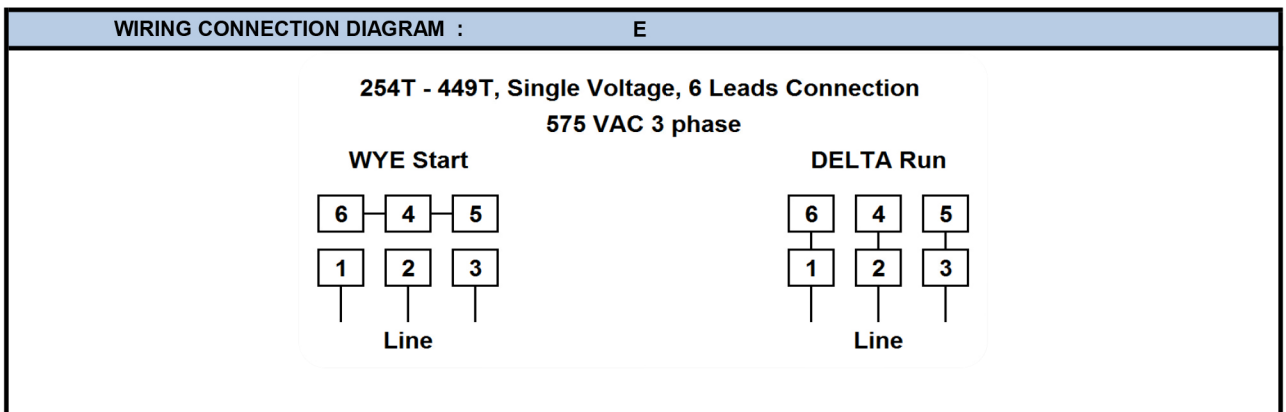

EPACT NR CAN NEMA 12 - 11										
HP	VAC	RPM	Enclosure	Frame	Frequency	Design	Poles	LR Code Letter	Insulation Class	Temp. Rise °C
15	575	3540	TEFC	254JP	60	B	2	G	F	52
Load %	0%	25%	50%	75%	100%	125%	150%			
Amps	5.20	6.27	8.50	11.20	14.00	17.86	21.21			
Torq ft/lbs	0	5.41	10.86	16.37	21.96	27.56	33.19			
RPM	0	3585	3570	3555	3540	3525	3510			
Eff	0	86.49	89.80	90.50	90.20	90.20	90.20			
PF	0	51.8	72.7	82	86	87.2	88.1			
	Locked Rotor	Pull-Up	Breakdown	Rated Load	Idle	Duty	S. F.	Ambient	Elevation	dBa @ 1M
Speed (RPM)	0	1512	2880	3540	3600	Continuous	1.15	40°C	3,300 ft	84
Current (Amps)	93	79.1	55.3	14	5.2	VFD Rating: Meets MG1 parts 31.4.4.2				
Torque (ft-lbs)	46.73	39.72	60.09	22.25	0.0	C.T.	2:1	V.T.	10:1	

Motor Speed Data

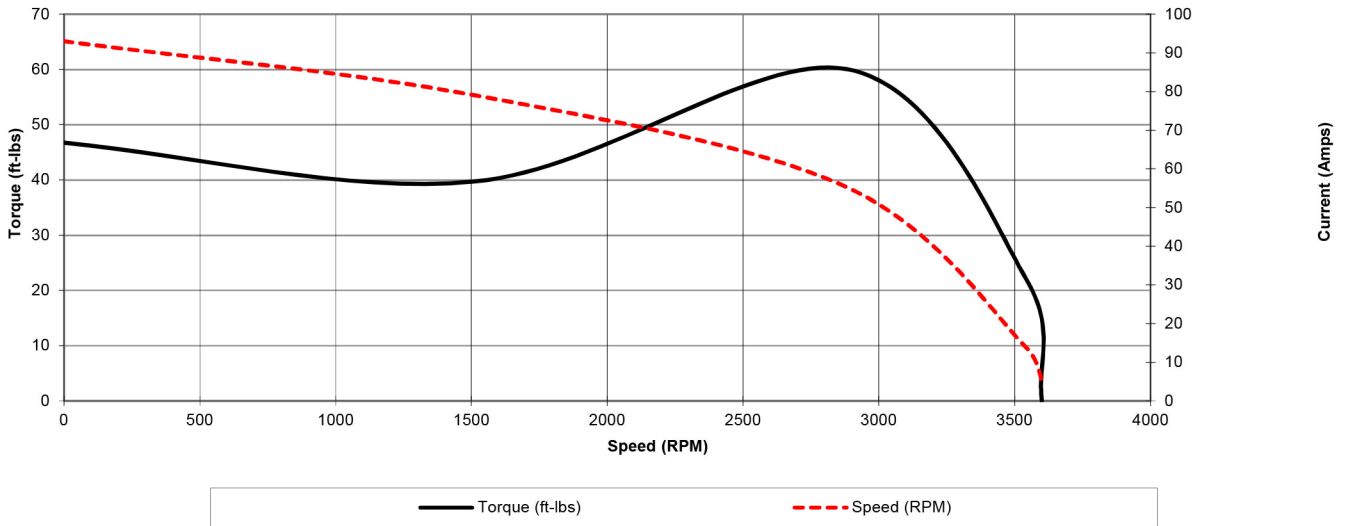

Motor Load Data

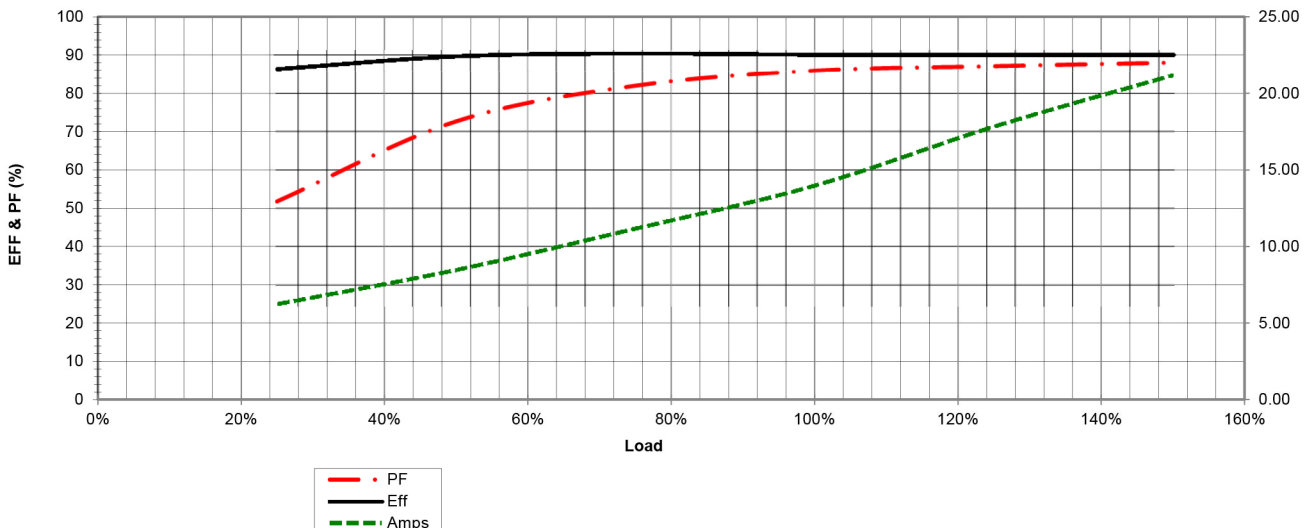

EPACT NR CAN NEMA 12 - 11

HP	VAC	RPM	Enclosure	Frame	Frequency	Design	Poles	LR Code Letter	Insulation Class	Temp. Rise °C
15	575	3540	TEFC	254JP	60	B	2	G	F	52

	0Hz	6Hz	15Hz	30Hz	45Hz	60Hz	75Hz	90Hz	105Hz	120Hz
Amps	14	14	14	14	14	14	14	14	14	14
RPM	0	354	885	1770	2655	3540	4425	5310	6195	7080
Torq ft.lb	17.80	17.80	22.25	22.25	22.25	22.25	17.80	14.84	12.72	11.13
Peak Tq ft.lb	26.15	52.30	52.30	52.30	52.30	52.30	41.84	34.86	29.88	26.15
HP	0	1.2	3.8	7.5	11.3	15.0	15.0	15.0	15.0	15.0

	Locked Rotor	Pull-Up	Breakdown	Rated Load	Idle	Duty	S. F.	Ambient	Elevation	dBA @ 1M
Speed (RPM)	0.0	1512	2880	3540	3600	Continuous	1.15	40°C	3,300 ft	84
Current (Amps)	93.0	79.1	55.3	14.0	5.2	VFD Rating: Meets MG1 parts 31.4.4.2				
Torque (ft-lbs)	46.7	39.7	60.1	22.3	0.0	C.T.	2:1	V.T.	10:1	

Motor Speed Data

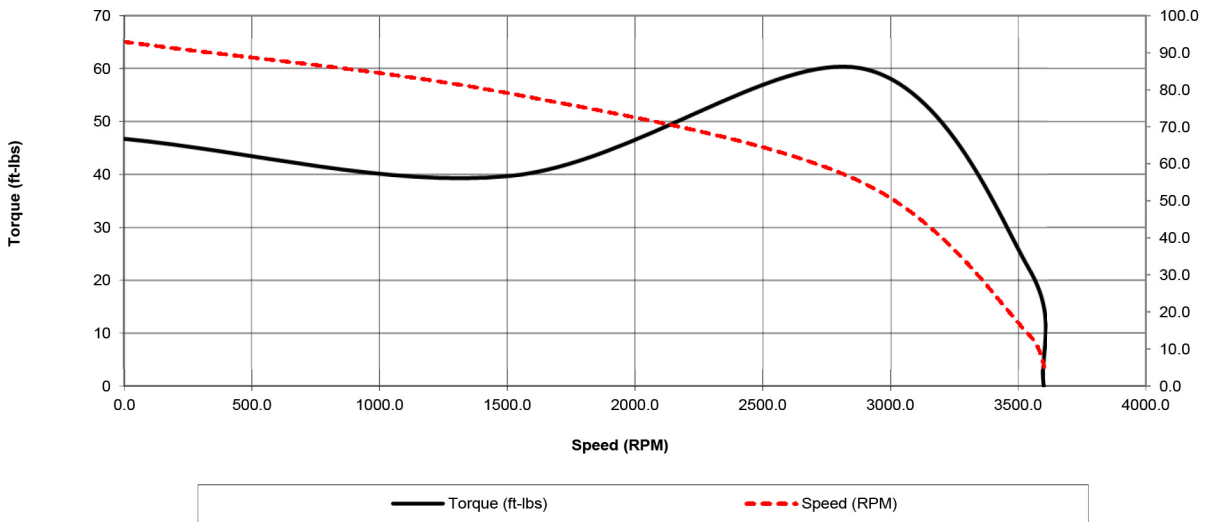

Motor Torque Capability vs RPM

